

Cimatron Solution for Die Making

From Quoting to Delivery

Forming
Shape
Form CS
Skin
Faces
Blank
Show
Analysis
Unfold
Bend
Unbend
Twist
Switch To
Strip

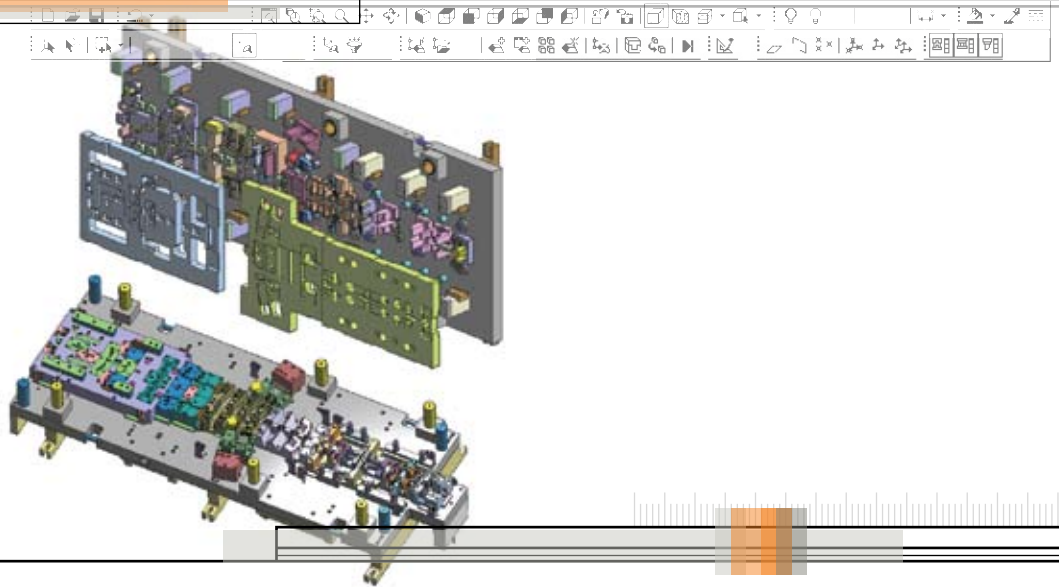

- Use an integrated solution dedicated to die making
- Deliver high quality dies at record times
- Produce dies at any complexity and size

Produce high quality dies at record times; increase your business competitiveness and profitability.

Weeks to Customer Delivery

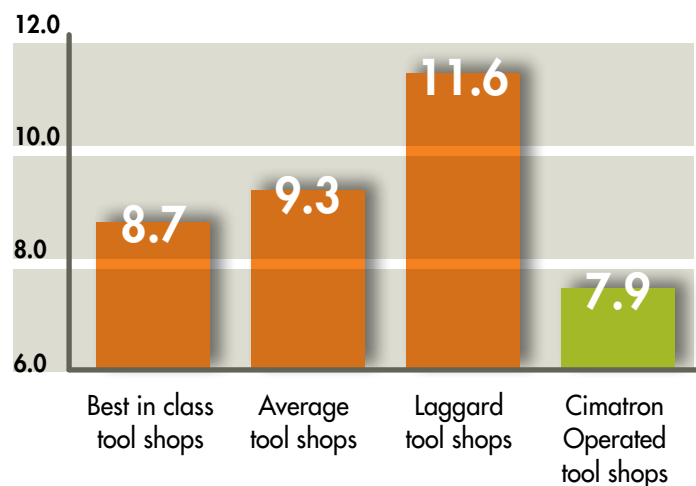

Cimatron Customers Deliver Tools Faster

Findings from the Aberdeen Group's Mold and Die Shop Benchmark study show that Cimatron customers are able to provide significantly faster delivery times than those offered by the rest of the industry.*

* Almost one week faster than shops classified as Best-In-Class, and as much as four weeks earlier than shops classified as Laggards.

The Benefits of Using Cimatron

Designed to meet the unique challenges faced by die makers today, Cimatron's die making solution enables you to:

- Win more jobs and increase profitability with faster, more accurate and professionally looking quotations.
- Undertake any project with the confidence to handle even the most complex parts.
- Dramatically reduce design time with powerful forming functions, built-in analysis tools, and the industry's fastest strip design capabilities.
- Optimize material utilization to lower product cost and increase your competitiveness.
- Automate repetitive and time consuming tasks to reduce delivery time and cost.
- Streamline processes and easily manage changes by using a single integrated solution from design to manufacturing.





What Makes Cimatron ideal for die makers?

An integrated solution from quoting to delivery

Cimatron's CAD/CAM solutions address the entire die making process—from quoting to design, applying engineering changes, NC and EDM programming. Nothing is lost in translation, so you can deliver higher quality tools at lower cost and shorter cycle times.

One-stop dedicated die design solution—complete any job at record time

Die makers no longer need to spend valuable time attempting to construct the unique features of a die using general-purpose CAD applications or switching between multiple systems. With built-in data converters, nesting capabilities, finite element analysis tools, and a blank calculation engine, you can get the entire design done in a single environment, allowing you to complete even the most complex job at unprecedented speed.

Flexible automation—the ideal mix of automation and user control

Cimatron's CAD/CAM solutions save die makers time with high level of automation, while empowering the experienced user with full flexibility to control the entire process. Cimatron's Intelligent Toolbox puts the right tool at your disposal at the right time—supporting and speeding up your natural workflow.

Design in 2D or 3D, using surface or solid operations—it's your call

2D or 3D, surface or solids are no longer a dilemma; Cimatron supports you whichever way you prefer to do your design work. Perform surfacing operations on solids and solid operations on surfaces using a complete hybrid environment to fit your preferences and the task at hand.

Machine any die component—from simple to complex, and everything in between

From simple 2.5-axis milling and drilling to complex 5-axis machining and micro milling, Cimatron provides the full range of NC technologies needed to get the job done.

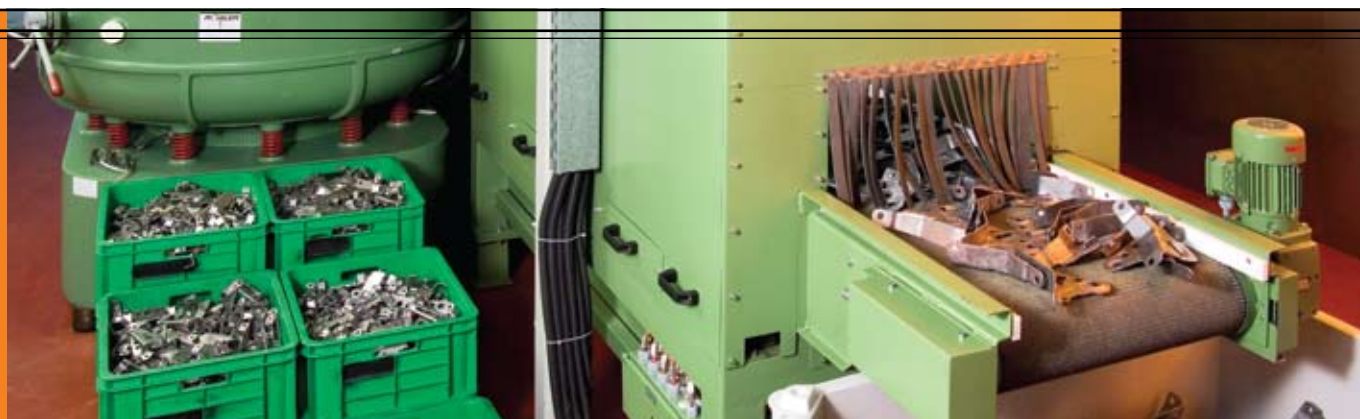

“

Cimatron has the best technical support I have ever seen.

Starbase Technologies, USA

”



Partnering for Success

Tooling is your business. It is also ours. With over 25 years of working with the tooling industry, we understand that success requires not only the best products, but also the know-how, process, and resources to help you make the most out of them.

Implement at your own pace with a modular or fully integrated solution

While Cimatron provides a complete integrated solution that covers the entire die making cycle, you can implement individual modules of the system at your own pace to address your most urgent needs and match your available resources.

Upgrade to Cimatron without losing productivity

The tooling experts at your local Cimatron office provide extensive training and implementation support to guarantee successful deployment and complete customer satisfaction. A proven implementation methodology includes a step-by-step integrated training and migration plan to ensure quick productivity ramp-up with minimum disruption to your business.

Tooling expertise and world-class customer support

With more than 20,000 installations worldwide, Cimatron is focused on serving the needs of the tooling industry. Cimatron's subsidiaries and extensive distributor network are located in over 35 countries to serve customers worldwide with complete pre- and post-sales support. Ongoing support is provided by your local office to ensure the highest level of responsiveness. Employees and representatives worldwide are tooling experts that utilize their industry knowledge to assist customers with unparalleled dedication and expertise.

Cimatron has a complete solution that helps you streamline the entire die making process from quoting to design and manufacturing.

Choice of a fully integrated or modular solution

Cimatron's CAD/CAM functionality covers the entire die making cycle—from quoting to design, applying engineering changes, NC and EDM programming—streamlining the entire die making process. The system is available as separate modules or as a complete integrated solution.

Quoting

Design

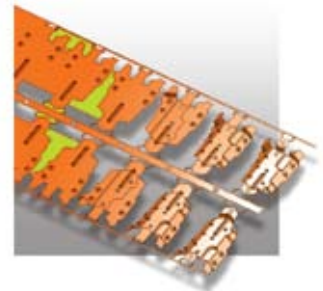

1 Data Import

2 Quoting

3 Blank Design & Forming

4 Strip Layout Design

Using Cimatron for the entire die making process makes us much more efficient than we were when we used different software packages for different tasks.

J. Englander Ltd., Israel

”

Manufacturing

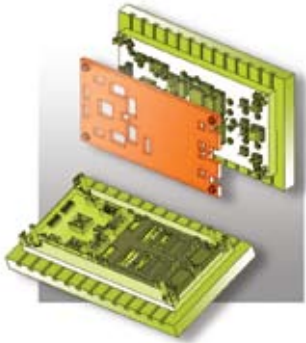

5 Die Tool Design

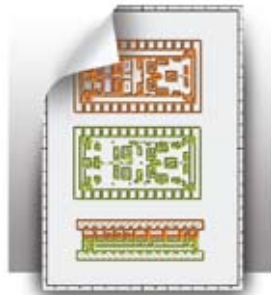

6 Drawing

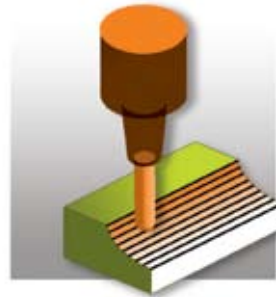

7 NC Programming



8 Wire EDM

Quoting

1



Data Import

Import your customer data and start working within seconds

- Start working as soon as you get your customer's part data. Heal and stitch data or work with non-stitched models and poor-quality imported data.
- Quickly and reliably import your customer part data with automatic data validation and highly accurate conversion from all standard formats, including DWG, DXF, IGES, STEP, VDA, Parasolid and SAT (ACIS).
- Take advantage of native read/write options for popular CAD systems, including CATIA, Pro/Engineer, SolidWorks and Unigraphics.

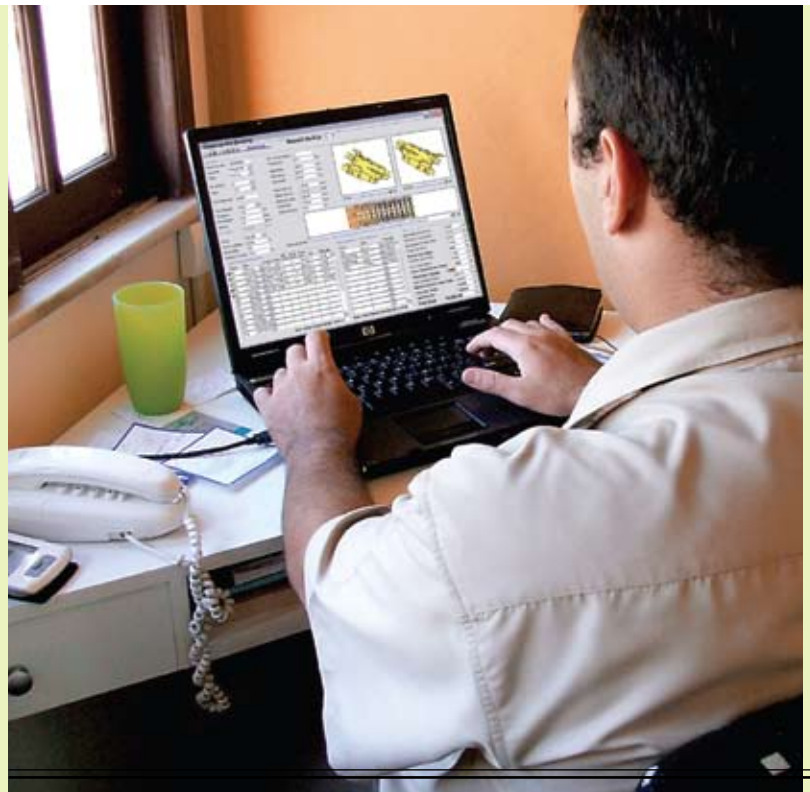
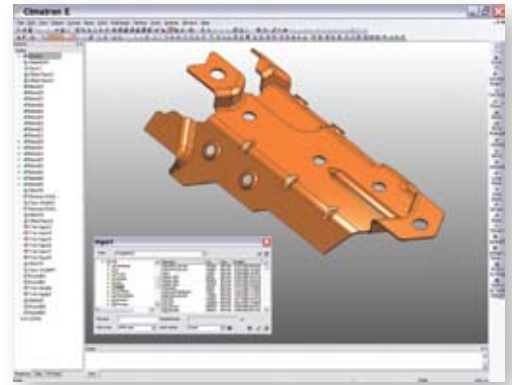

“Thanks to DieDesign, we are able to win more business... we are establishing a quotation at an average of only one hour ...Prior to DieDesign, we needed six hours.

Ernst Keller GmbH, Germany

”

2



Quoting

Win more business with quick and accurate cost estimates

- Calculate blanks in record times using the industry's fastest blank design capabilities.
- Figure out material requirements and utilization in minutes rather than hours with efficient nesting:
 - Determine the number of progressions (stations)
 - Progression distance (pitch)
 - Strip width
 - Blank location and angle
 - Carrier shape and position
- Get a clear understanding of part formability and job complexity using built-in Finite Element Analysis.
- Incorporate preliminary design images to produce highly professional-looking quotes.
- Use *Quick Compare* to clearly visualize and analyze engineering changes (ECO) made in the original part, for accurate and efficient cost estimates of the required changes.

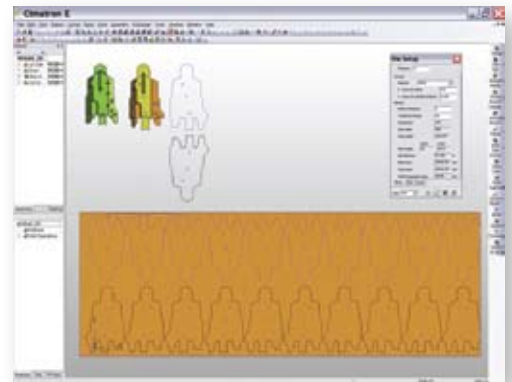

Design

3



Blank Design & Forming

Create and edit forming shapes quickly and easily

- Work in an intuitive environment to create and try out different forming shape options. Select your preferred forming shapes to compose your strip.
- Perform automated blank calculation or user-controlled flattening on the entire part or specific sections of it.
- Eliminate hours of manual work using Auto Blank on Binder to unfold freeform shapes onto a 3D geometry.
- Utilize special geometric tools incorporating spring back compensation calculations for bending, unbending, unfolding, twisting, flanging, and other forming operations.
- Work the way that best fits your needs with powerful solid, surface, and wireframe functions.
- Use built-in Finite Element Analysis tools to perform real-time thinning and safety zone analysis; on-screen indicators provide real-time curvature maps, draft angle analysis, and other input required for force calculation.
- Save time and eliminate errors by automatically transferring the information created in the forming phase to the die tool design environment.

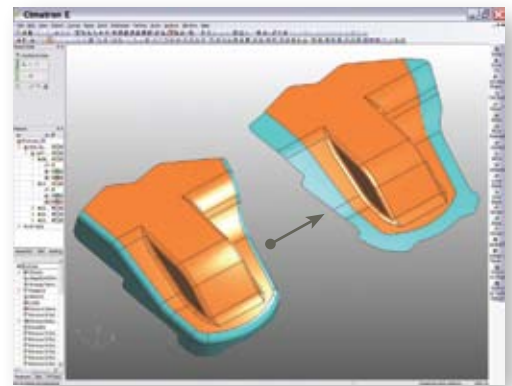

Unfolding a freeform shape onto a 3D geometry

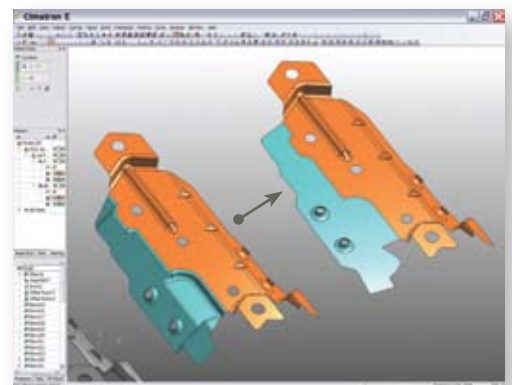

Blanking operation on a specific section of the part

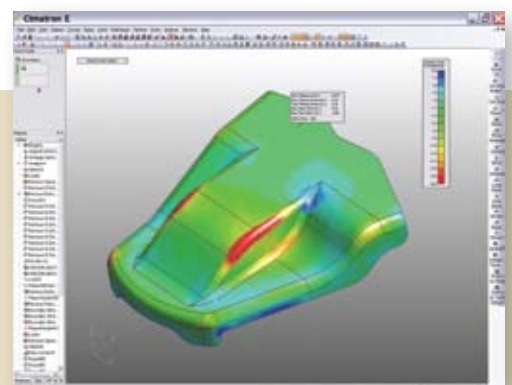

Safety Zone Analysis



Cimatron's DieDesign shortens weeks of work into days.

CAM Tool & Die, Canada

4

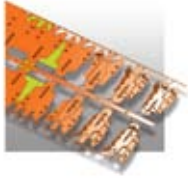

Strip Layout Design

Increase productivity with time-saving automation and full flexibility

- Enjoy complete flexibility to determine the number of progressions (stations), progression distance (pitch), strip width, blank location, blank angle, distance between rows and other nesting parameters.
- Make and view changes on-the-fly with real-time simulation and validation.
- Create and relocate trimming punches, carriers and pilots at incredible speed while visualizing the impact of each cut operation on the remaining strip.
- 'Pick and drop' your selected freeform shape from the shape forming area into the strip to achieve your desired strip/transfer layout.
- Designers used to working in 2D will enjoy Cimatron's Strip Layout Design environment, offering a similar 2D working experience with additional productivity enhancing features.

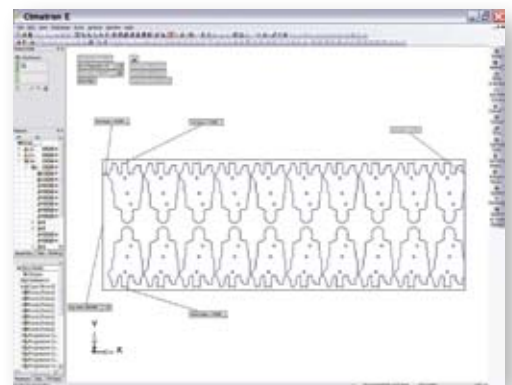

Strip layout dimensions with on-screen indications and real time simulation

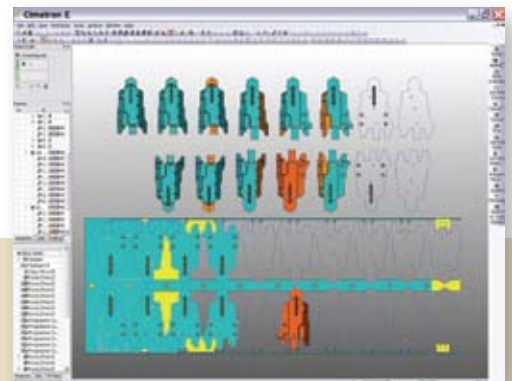

Visualize the impact of each operation on the remaining strip
'Pick and drop' selected freeform shapes onto the strip

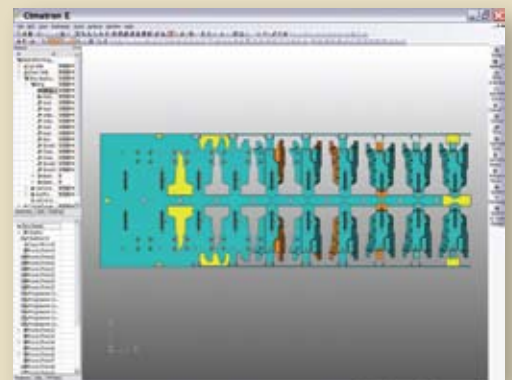

Easy viewing of each station on the strip

Design

5



Die Tool Design

Design a high quality tool faster and at a lower cost

- Create your own parametric and associative mechanisms (die set configuration, punch units, forming units...) containing knowledge such as offsets between plate and punches and build a library of all mechanisms for instant reuse.
- Save days of work with automated design of the die set assembly using the intelligent mechanisms from your library.
- Use any standard catalogue to build your die set.
- Add multiple catalogue parts in seconds and leverage the knowledge of features retained by the application to speed up design and ensure manufacturability.
- Instantly modify the die set at any stage of the design process.
- Utilize die validation tools with built-in measurement, analysis, and collision detection capabilities.
- Allow multiple users to simultaneously work on the same assembly, significantly compressing design cycle times.
- Users of Cimatron's NC solution enjoy automatic transfer of data to the NC environment to speed up the tool manufacturing.
- Engineering Change Orders (ECO) are fully supported.

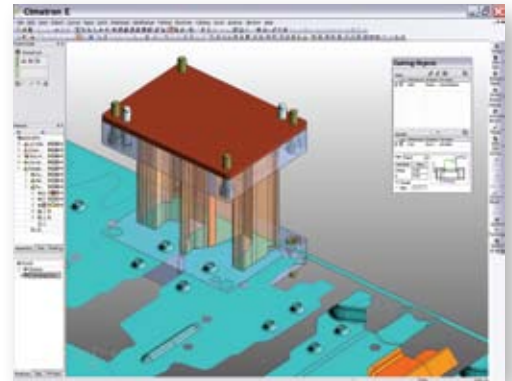

Trimming punch creation

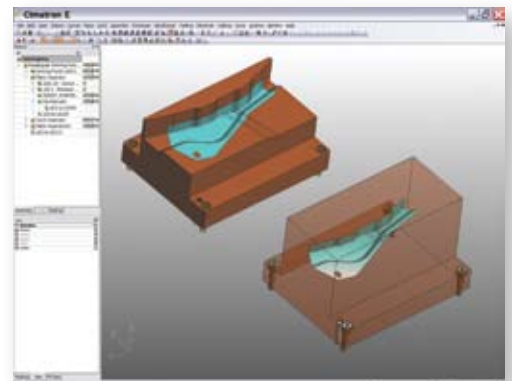

Forming punch creation

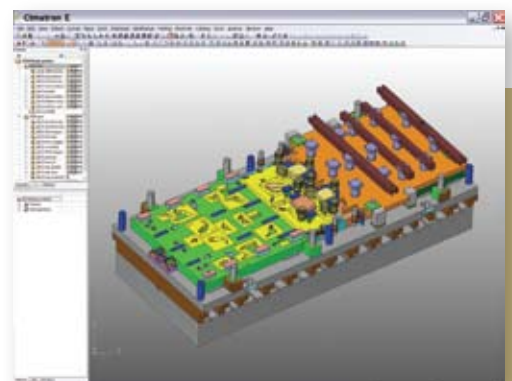

Die Set

6



Drawing

Create and reuse drawing templates incorporating customer specifications

- Use powerful drafting options for strip and die tool drawings.
- Eliminate repetitive manual steps with automated generation of BOM and table of holes.
- Generate drawings with all the information needed for ordering components, shop floor operators, quality assurance, and customer documentation.
- Define drafting views on-the-fly during the modeling process; then quickly convert them into drawings.
- Create and reuse templates incorporating customer standard drawing specifications.

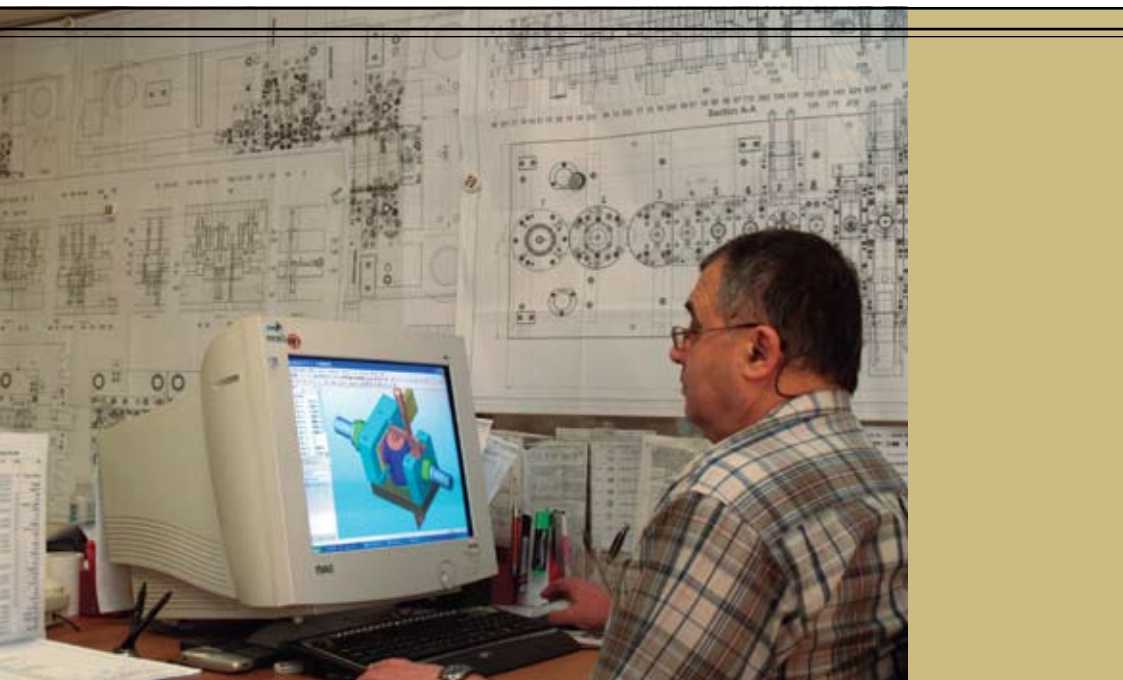
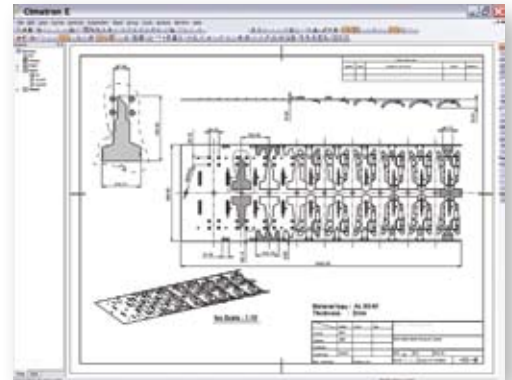
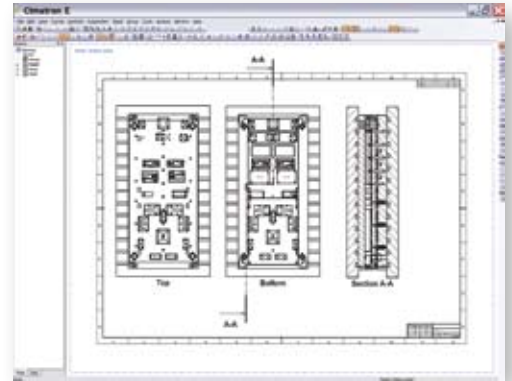

Manufacturing

7



NC Programming

Use Cimatron's NC module to turn your die design into a prototype or fully functioning production die tool with unprecedented accuracy and speed.

Cimatron NC is the natural choice for die makers, available as either a stand-alone module or fully integrated with the die design modules for a complete end-to-end solution.

Using Cimatron NC as part of an end-to-end integrated solution, you can:

- Save time and eliminate errors by seamlessly transferring all geometrical attributes from the design phase to the NC programming phase without any data conversion.
- Easily manage engineering changes with built-in associativity — changes you make in the tool design flow directly to the affected NC procedure.
- Compress delivery cycles with concurrent engineering capabilities that allow you to begin manufacturing selected tool assembly components while continuing the design of others.

Rich Built-in CAD Functionality

All the CAD you need for best machining results

- Built-in CAD mode with robust surfacing capabilities allows the NC programmer to optimize machining by adding surfaces and contours and easily correcting geometry issues such as capping holes, applying drafts, rounds and surface extensions.

Automated Drill

Save up to 90% of drill programming time

- Adaptive, accurate and easy-to-use drilling functionality for applications ranging from plate machining to 5-axis production and gun drilling.
- Hundreds of holes can be recognized in seconds and are automatically assigned the appropriate drilling sequence.
- Stock recognition capabilities take into consideration the stock existing above the hole before it is drilled, enabling the assignment of an optimal drilling sequence.
- Users of Cimatron's fully integrated solution enjoy automatic transfer of hole properties assigned during the tool design phase, such as thread, accuracy and surface quality – saving huge amount of time and eliminating errors.

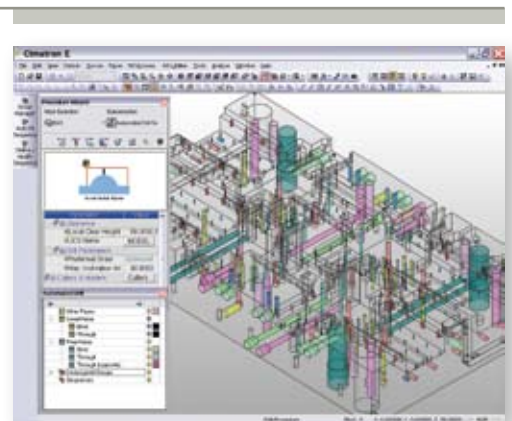

“Since Cimatron is a fully integrated suite, we have eliminated the need to transfer data between different systems and so we don't experience data loss and time loss.

J. Englander, Israel

”

Efficient Roughing Functionality

Maximize material removal rate while prolonging tool life

- Built-in NC-Preview function enables to preview machining results in a matter of seconds, allowing programmers to optimize machining strategies and eliminate errors early in the process.
- Stock is continuously updated throughout the various orientations, generating an efficient toolpath for any selected machining strategy.
- Tool shank and holder collision checking against the auto-updated stock is performed automatically at all stages of Rough and ReRough operations.
- For highly-productive High-Speed Milling (HSM) and long tool life, the system generates an all-rounded toolpath with constant tool load, trochoidal milling, advanced clean between passes, efficient rough between layers, and state-of-the-art ridge removal.

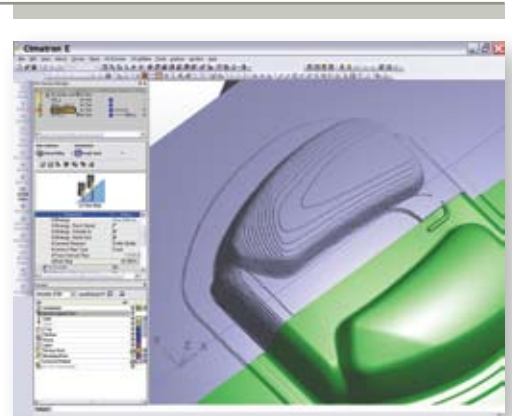

Preview machining results in seconds

High Quality Finishing

Achieve polish-less surface quality

Robust 3 to 5-axis finishing application, providing optimized machining strategy for any model shape. Based on slope and curvature analysis, part geometry, and tool accessibility, finishing machining strategies include:

- Adaptive Z layers
- True spiral motions
- All rounded motions
- Flow-line machining
- Cleanup (rest machining) and pencil
- Slope controlled finishing
- Optimized CBP (Clean between passes)
- Unique Ridges handling by Zero Overlap trochoidal

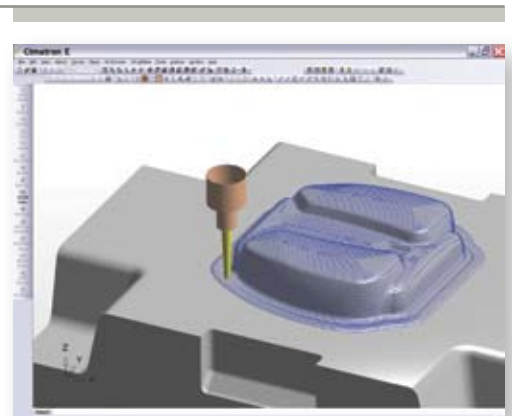

Manufacturing

Advanced Micro Milling

For miniature and high precision milling

Cimatron is a pioneer in the field of micro milling, offering dedicated micro-machining strategies for cost-effective manufacturing of dies for very small, high precision parts.

- Generate superb surface quality with tolerances as tight as 0.0001mm, using cutting tools with diameters down to 0.1 mm.
- Use Cimatron's micro milling capabilities to support cutting-edge Direct Milling.

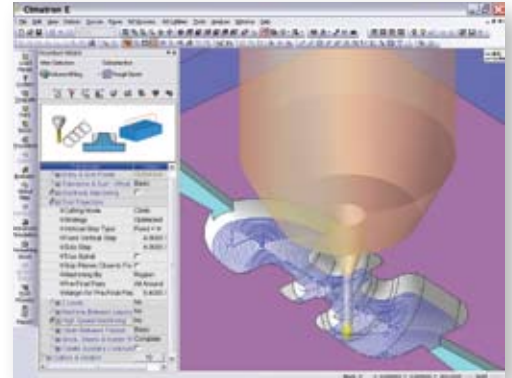

Full 5-Axis functionality for die making

Reduce setup time, shorten machining time, and improve surface quality

- Advanced simulation capabilities—including material removal, remaining stock, and complete machine kinematics—allow operators to review the machining process prior to manufacturing and eliminate unnecessary tryouts.
- A large library of machining strategies support a complete range of cutters including tapered cutters, lollipop tools, and slot mill cutters.
- Supports positioning and continuous milling, providing full control over the tilt and lead angles as well as gouge and collision check of the various tool shank and holder against the part.
- Touch-of-a-button 5-axis tilting solution is especially suitable for rapid machining of parts with deep cavities, narrow ribs and tiny corner radiuses, using shorter and more rigid tools for best surface quality and reduced machine time.
- Utilize a single setup for multi-side operations.

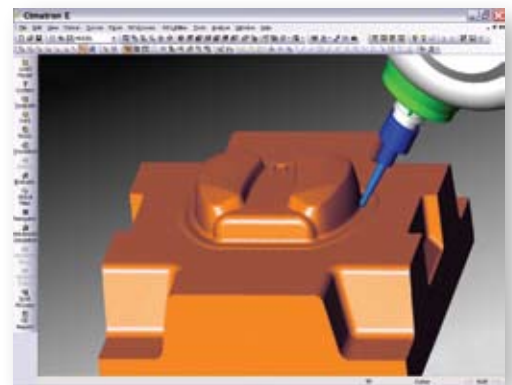

The Right Balance of Automation and Manual Control

Enjoy the speed of automation without losing flexibility

- Cimatron offers automation options to create programs in minutes, while still enabling operators to use a rich set of advanced parameters to control toolpath strategy and machining conditions.
- Initial steps can be quickly accomplished with user-friendly guides and reusable templates while control remains firmly in the hands of the experienced programmer.
- Advanced template functionality further automates programming, allowing the reuse of specific procedures and even complete machining processes.
- Easy template management helps retain crucial company knowledge—capturing expertise and know-how for future use.

NC Setup and Tool Table Reports

Facilitate information flow between NC programmers and the shop floor

- NC Setup and Tool Table reports can be generated automatically as you post-process a program or as separate action.
- Reports provide the machine operator with all relevant information including minimal and maximal dimensions, a picture of the setup, the entire tool list with all relevant parameters, and complete statistics of expected machining time per tool and for the entire job.
- Customizable reports for the shop floor can be modified to include company logo, machine time, machine limits, and other user-specific data and parameters.

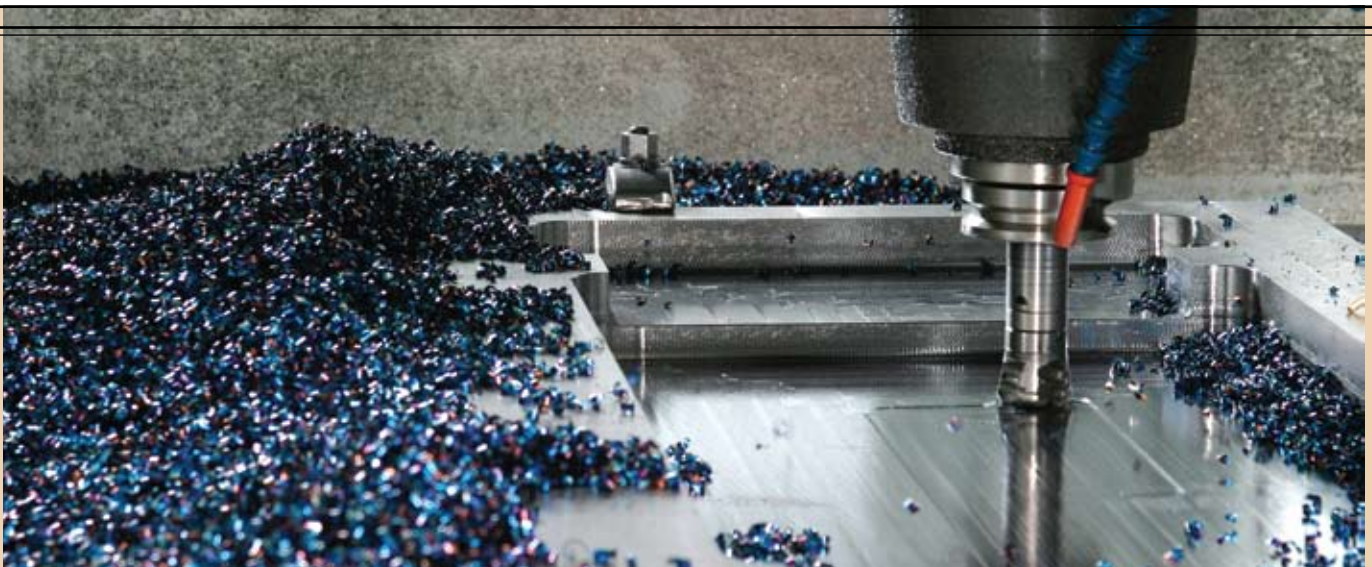

Manufacturing

Simulation & Post-Processor Support

Machine with confidence and predict results

- Simulation and verification allow you to view the cutting process and its results prior to machining, with color-coded display to help you analyze the remaining material around the part.
- A rich library of post-processors is offered for practically all 3-axis and 5-axis machines as well as all leading controllers.
- A state-of-the-art post-processor generator can be easily customized to any specific need.
- Advanced simulation generated with the G-code, simulates real machine kinematics and tool path motion, checking tool shanks and holders against the part. The ability to predict machine behavior enables errors to be corrected and eliminated ahead of time.

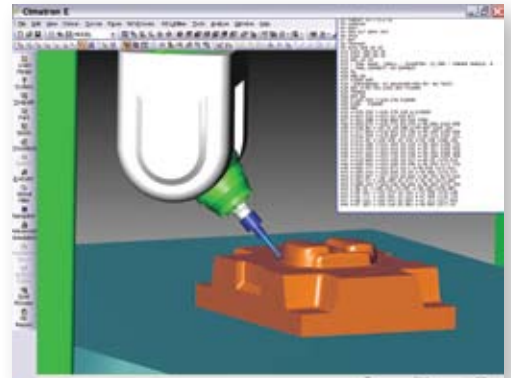

8



Wire EDM Programming

Quickly and easily program your Wire EDM machines

- Supports 2-axis and 4-axis wire modes.
- 4-axis mode handles single contour with either constant or variable conic, automatically synchronizing upper and lower profiles while giving you a manual override option.
- A built-in database of EDM machines assures optimal CNC performance.
- CAM Process Manager guides you through the entire EDM process.
- Process templates for Knowledge Based Machining allow you to define your own custom settings and combine multiple processes into a single template, including complete wire path simulation.

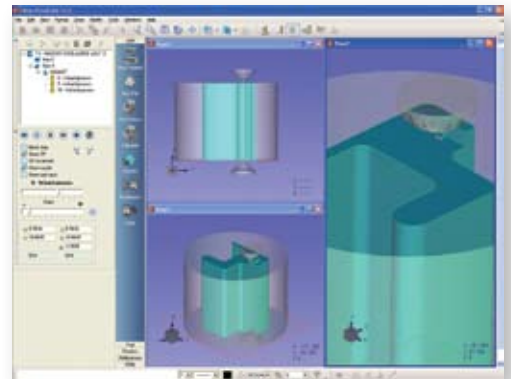

If you are looking to step up
to the 21st century,
Cimatron has the solution for you.

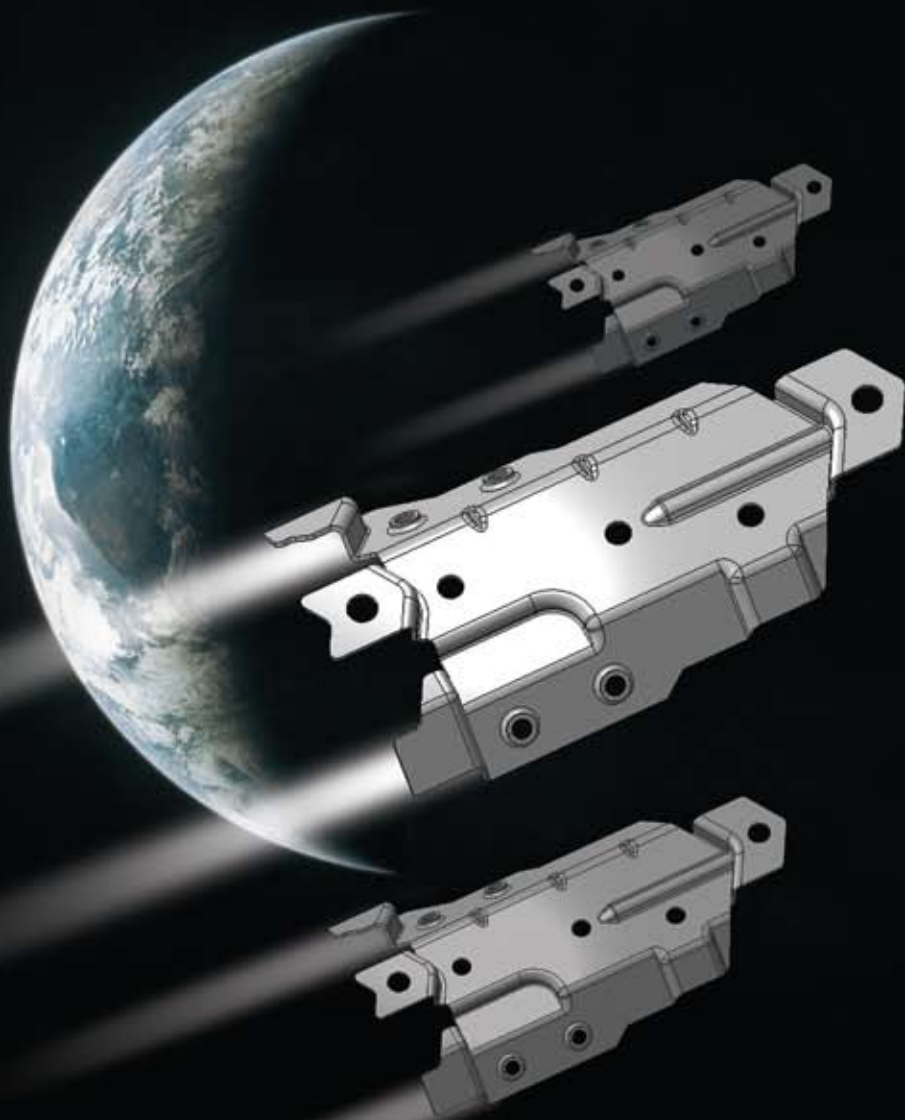

-  Forming Shape
-  Form CS
-  Skin
-  Faces
-  Blank
-  Show Analysis
-  Unfold
-  Bend
-  Unbend
-  Twist
-  Switch To Strip

About Cimatron

With more than 20,000 installations worldwide, Cimatron is a leading provider of integrated, CAD/CAM solutions for mold, tool and die makers as well as manufacturers of discrete parts. Cimatron is committed to providing comprehensive, cost-effective solutions that streamline manufacturing cycles, enable collaboration with outside vendors, and ultimately shorten product delivery time. Cimatron's cutting-edge CAD/CAM solutions are widely used in the automotive, medical, consumer plastics, electronics, and other industries.

Founded in 1982, Cimatron is publicly traded on the NASDAQ exchange under the symbol CIMT. Cimatron's subsidiaries and extensive distributor network are located in over 35 countries to serve customers worldwide with complete pre- and post-sales support.

For more information, please visit our web site at:
www.cimatron.com

Images courtesy of J. Englander Ltd. Israel

